

COMMERCIAL RECYCLING EQUIPMENT



BIN PRESS

BP1100

THE BENEFITS

- ✓ Safe and easy to operate
- ✓ Saves space (Avg. 3:1 compaction ratio)
- ✓ Fewer collections required
- ✓ Improved site sanitation & safety
- ✓ Uses minimal floor space
- ✓ Considerable financial savings
- ✓ Environmentally friendly



Visit www.pearce-group.co.uk
or call us on **0800 083 3333**

Dimensional Data

| | |
|---------------------|------------|
| Overall Width | 955mm |
| Overall Depth | 1522mm |
| Overall Height | 2585mm |
| Back Wall Clearance | 500mm |
| Side Wall Clearance | 500mm |
| Bin Capacity | 1100 litre |
| Machine Weight | 350kg |

Electrical Specification

| | |
|-----------------|--------|
| Supply Voltage | 230vac |
| Phase | 1ph |
| Max Current | 13A |
| IP Rating | IP55 |
| Control Circuit | 24vdc |

Machine Specification

| | |
|------------------|----------|
| Compaction Ratio | Avg. 3:1 |
| Compaction Force | 3 tonnes |
| Motor | 1.1kw |
| System Pressure | 85 bar |
| Cycle Time | 27 secs |
| Pump | 7 lpm |



“ This Bin Press has really helped our company a lot in saving space by reducing our bins for general waste and recycling. It has made great savings also. This has been a God send for us and we would certainly use Pearce Compaction Systems again if we needed any more equipment.

Graeme Cole
Captains Club Hotel

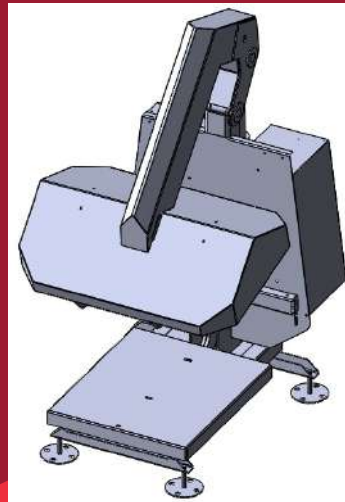

GET IN TOUCH



Pearce Group Head Office
Pearce House, Acrewood Way,
St Albans, Hertfordshire, AL4 0JY

Email: compaction@pearce-recycling.co.uk
Web: www.pearce-group.co.uk
Call: 0800 083 3333

