

## COMMERCIAL RECYCLING EQUIPMENT



# MIDI BALER

## HB160

### THE BENEFITS

- ✓ Safe and easy to operate
- ✓ Saves time & space
- ✓ Can generate a revenue
- ✓ Easy to store & transport bales
- ✓ Small footprint
- ✓ Environmentally friendly
- ✓ Average bale 160-170kg
- ✓ Complies to BS EN 16500:2014



Visit [www.pearce-group.co.uk](http://www.pearce-group.co.uk)  
or call us on **0800 083 3333**

### Dimensional Data

Overall Width	1400mm
Overall Depth	945mm
Overall Height	2280mm
Feed Height	870mm
Bale Chamber Depth	700mm
Load Aperture Width	1080mm
Load Aperture Height	600mm
No. of Ties (9mm tape)	4
Back Wall Clearance	500mm
Side Wall Clearance	300mm
Machine Weight	650kg

### Electrical Specification

Supply Voltage	230vac
Phase	1ph
Max Current	13A
IP Rating	IP55
Control Circuit	24vdc

### Machine Specification

Compaction Force	10 tonnes
Motor	2.2kw
System Pressure	95 bar
Cycle Time	50 secs
No. of Rams	2
Cylinder Stroke	700mm
Cylinder Bore	80mm
Pump	11.3 lpm

### Bale Size

Width	1080mm
Depth	680mm
Height	800mm
Weight	160-170kg



Having the Pearce compactors on site has greatly reduced our waste bill; they have also enabled us to sort our recycling more efficiently through use of the cardboard balers and the RotorPac for waste plastic packaging. During our 10+ year relationship with Pearce Compaction we have found all areas of the business from the office to the service engineers to have a professional and positive attitude towards our custom.

**Trevor Fears**  
Amsafe

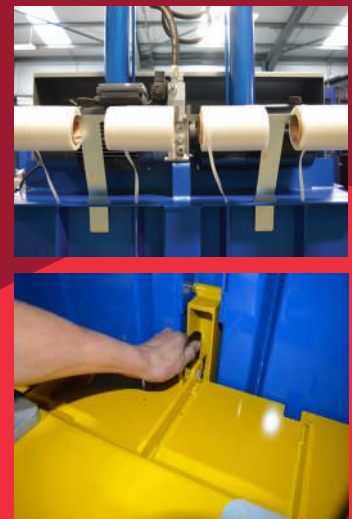
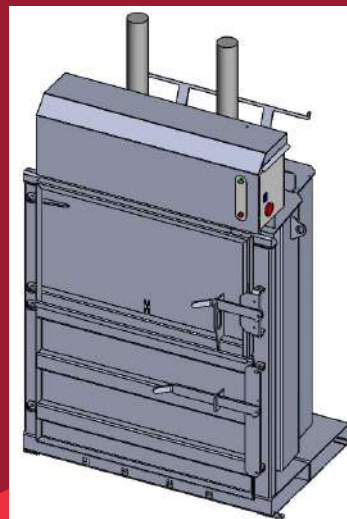

## GET IN TOUCH



**Pearce Group Head Office**  
Pearce House, Acrewood Way,  
St Albans, Hertfordshire, AL4 0JY

Email: [compaction@pearce-recycling.co.uk](mailto:compaction@pearce-recycling.co.uk)  
Web: [www.pearce-group.co.uk](http://www.pearce-group.co.uk)  
Call: **0800 083 3333**

