

**COMMERCIAL RECYCLING  
EQUIPMENT**



# MILL SIZE BALER

## HB450

### THE BENEFITS

- ✓ Average bale 400 - 450kg
- ✓ Can generate a revenue
- ✓ Easy to store & compact to transport
- ✓ Saving on carriage costs
- ✓ Safer, tidier site, with more room
- ✓ Easy & safe to operate
- ✓ Environmentally friendly
- ✓ Complies to BS EN 16500:2014



Visit [www.pearce-group.co.uk](http://www.pearce-group.co.uk)  
or call us on **0800 083 3333**

#### Dimensional Data

|                          |        |
|--------------------------|--------|
| Overall Width            | 1710mm |
| Overall Depth            | 1357mm |
| Overall Height           | 3040mm |
| Feed Height              | 1060mm |
| Bale Chamber Depth       | 800mm  |
| Load Aperture Width      | 1200mm |
| Load Aperture Height     | 1000mm |
| No. of Ties (Cut & Loop) | 4      |
| Back Wall Clearance      | 500mm  |
| Side Wall Clearance      | 300mm  |
| Machine Weight           | 1700kg |

#### Electrical Specification

|                 |        |
|-----------------|--------|
| Supply Voltage  | 415vac |
| Phase           | 3ph    |
| Max Current     | 32A    |
| IP Rating       | IP55   |
| Control Circuit | 24vdc  |

#### Machine Specification

|                  |           |
|------------------|-----------|
| Compaction Force | 25 tonnes |
| Motor            | 7.5kw     |
| System Pressure  | 140 bar   |
| Cycle Time       | 53 secs   |
| No. of Rams      | 1         |
| Cylinder Stroke  | 1000mm    |
| Cylinder Bore    | 150mm     |
| Pump             | 34 lpm    |

#### Bale Size

|        |           |
|--------|-----------|
| Width  | 1200mm    |
| Depth  | 800mm     |
| Height | 1000mm    |
| Weight | 400-450kg |



Having the Pearce compactors on site has greatly reduced our waste bill; they have also enabled us to sort our recycling more efficiently... During our 10+ year relationship with Pearce Compaction we have found all areas of the business from the office to the service engineers to have a professional and positive attitude towards our custom.

**Trevor Fears**  
Amsafe

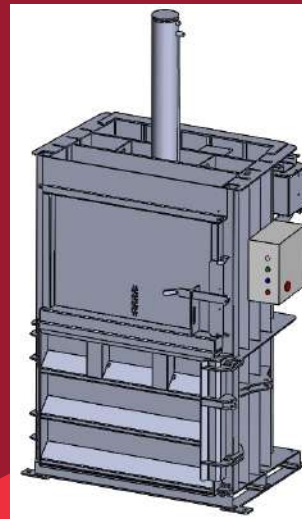

## GET IN TOUCH



**Pearce Group Head Office**  
Pearce House, Acrewood Way,  
St Albans, Hertfordshire, AL4 0JY

Email: [compaction@pearce-recycling.co.uk](mailto:compaction@pearce-recycling.co.uk)  
Web: [www.pearce-group.co.uk](http://www.pearce-group.co.uk)  
Call: 0800 083 3333

