

**COMMERCIAL RECYCLING  
EQUIPMENT**



# MOBILE COMPACTOR

**MC14BL**

## THE BENEFITS

- ✓ Safe & easy to operate
- ✓ Cuts uplifts & transport costs
- ✓ Has a  $\frac{3}{4}$  full & full indicator
- ✓ Liquid retentive
- ✓ Saves space (Up to 4:1 compaction ratio)
- ✓ Odour free, tidier & more efficient site



Visit [www.pearce-group.co.uk](http://www.pearce-group.co.uk)  
or call us on **0800 083 3333**

**Dimensional Data**

Overall Width	1796mm
Overall Length	4680mm
Overall Height	2250mm
Machine Weight	3500kg
Machine Capacity	9m <sup>3</sup>

**Electrical Specification**

Supply Voltage	415vac
Phase	3ph
Max Current	32A
IP Rating	IP55
Control Circuit	24vdc

**Machine Specification**

Compaction Force	28275
Motor	5.5kw
System Pressure	180 bar
Cycle Time	49 secs
Bin Lift	240l - 1100l
75% Full Light	
100% Full Light	

**Optional Features**

SmarTec (status notifications)
SolarPac (solar power)



Having this Pearce Compactor on site has greatly reduced our waste bill. It also means we don't have lots of bins dotted around the site anymore really helping to keep our site nice & tidy.

We recommend this machine where space is an issue as it works well for those restricted on space like ourselves

We continue to work with Pearce Compaction Systems due to their pricing, service and ongoing reciprocal relationship.

**Robert**

**Food Industry**

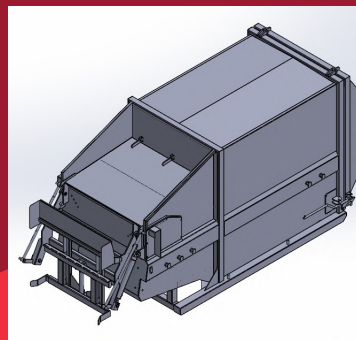

**GET IN TOUCH**



**Pearce Group Head Office**  
Pearce House, Acrewood Way,  
St Albans, Hertfordshire, AL4 0JY

Email: [compaction@pearce-recycling.co.uk](mailto:compaction@pearce-recycling.co.uk)  
Web: [www.pearce-group.co.uk](http://www.pearce-group.co.uk)  
Call: **0800 083 3333**

